

1. Objective

- To develop and evaluate an on-line algorithm for simultaneously tuning the consequent weights and the FOU associated with the antecedent fuzzy sets of a type-2 fuzzy controller.

2. Control Scheme

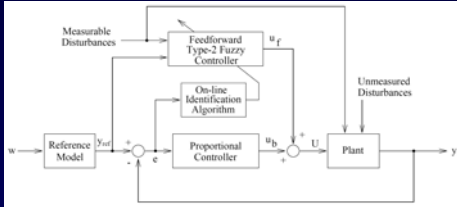

- Control scheme comprises a *reference model*, a *proportional controller* in a feedback configuration, and a type-2 fuzzy controller in a *feedforward* configuration.

- Required feedforward control signal, $u_d(t)$, estimated by

$$u_d(t) - u_f(t-1) = \gamma e(t), \quad \gamma = \text{constant}$$

where $u_f(t-1)$ is the output of the feedforward controller.

- Rule base is of the form

$$R_i : \text{If } r \text{ is } \tilde{R}_i^a \text{ and } \tilde{R}_i^b \text{ then } u_f \text{ is } w_i$$

- \tilde{R}_i^a is a type-2 fuzzy set. Proposed algorithm adjusts w_i , a , b , c , and d on-line.

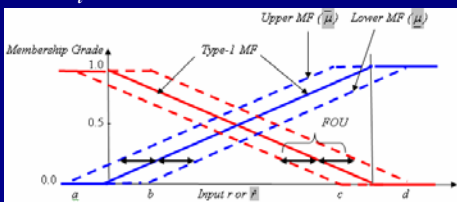

3. Learning algorithm

- Algorithm optimizes $J(t) = 0.5 e(t)^2$.

- Update rules for w_i and FOU are :

$$1 \leq i \leq X$$

$$\Rightarrow w_i(t) = w_i(t-1) + \delta \cdot e(t) \cdot (\overline{q_i^+} + \underline{q_i^+}), \quad \delta = \frac{\eta}{2\gamma}$$

$$X+1 \leq i \leq M$$

$$\Rightarrow w_i(t) = w_i(t-1) + \delta \cdot e(t) \cdot (\underline{q_i^+} + \overline{q_i^+}), \quad \delta = \frac{\eta}{2\gamma}$$

$$1 \leq i \leq X \Rightarrow$$

$$FOU_a(t) = FOU_a(t-1) + \delta \cdot e(t) \cdot \left(\frac{w_i}{N_i} \right) \cdot \left(\overline{\mu_{\tilde{R}_i^a}} \cdot \frac{\partial \overline{\mu_{\tilde{R}_i^a}}}{\partial FOU_a} \right), \quad \delta = \frac{\eta}{2\gamma}$$

$$X+1 \leq i \leq 4 \Rightarrow$$

$$FOU_a(t) = FOU_a(t-1) + \delta \cdot e(t) \cdot \left(\frac{w_i}{N_r} \right) \cdot \left(\overline{\mu_{\tilde{R}_i^a}} \cdot \frac{\partial \overline{\mu_{\tilde{R}_i^a}}}{\partial FOU_a} \right), \quad \delta = \frac{\eta}{2\gamma}$$

4. Results : pH control

- pH value manipulated by varying base flowrate q_3 . Acid (q_1) and buffer stream (q_2) are disturbances.

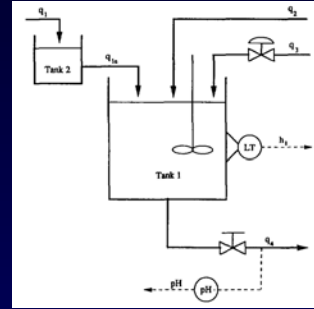

pH control using Type-1 fuzzy controller

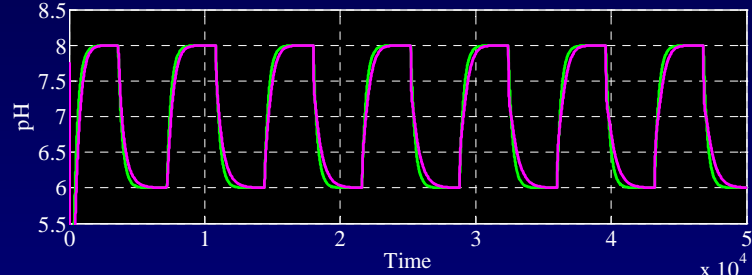

pH control using Type-2 fuzzy controller

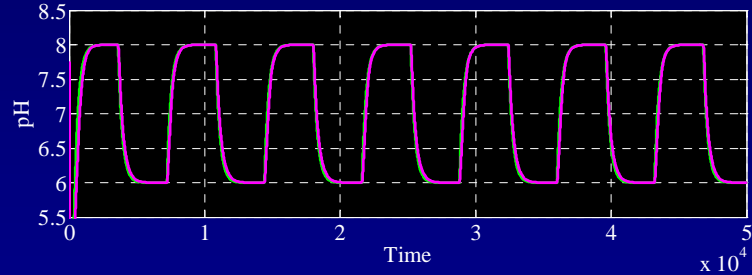

- ☺ **Type-2 controller provides a 24% improvement in IAE and a 35.3% improvement in ITAE values.**

- Comparison of ability to reject disturbances due to variations in buffer and acid flowrate.

